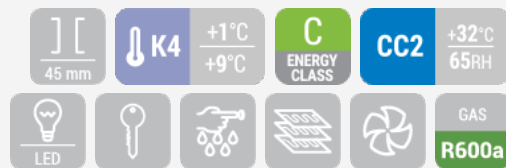

DRINKS | Vetrine bibite

DRINK COOLERS ► COOLER VERTICALI

RCF 85

CUSTOMIZATION AVAILABLE
 PERSONALIZZAZIONE DISPONIBILE

DETTAGLI



Ventilatore interno di assistenza



Serratura di serie



CARATTERISTICHE GENERALI

Drink cooler verticali 85 Lt.	•
Esterno in lamiera verniciata bianca, interno in termoformato bianco	•
Refrigerazione Roll-Bond con ventilatore di assistenza	•
Sbrinamento manuale	•
Schiumatura in Ciclopentano (45mm di spessore per lato)	•
Guarnizione Estraibile	•
Interuttore indipendente per le luci interne	•
Doppio vetro temperato di sicurezza	•
Termómetro digitale	•
Porta reversibile	•
Serratura di serie	•
Ripiani regolabili (Colore Bianco): 3 Pcs	•
N.4 Piedini regolabili	•
Classe energetica: C	•

SPECIFICHE TECNICHE

Capacità	85 L
Temperatura	K4 (+1°C-+9°C)
Consumo	2.68 kWh/24h
Potenza Nominale	65 W
Rumorosità	46 dB(A)
Peso Netto	35 Kg
Peso Lordo	38 Kg
Dimensioni Esterne (LxPxH mm)	505x590x780
Dimensioni Interne (LxPxH mm)	410x395x625
Dimensioni Imballo (LxPxH mm)	580x620x810
Quantità di carico 20'/40'/40'HQ	72/158/228

CERTIFICAZIONI



 RoHS

INGOMBRO PRODOTTO

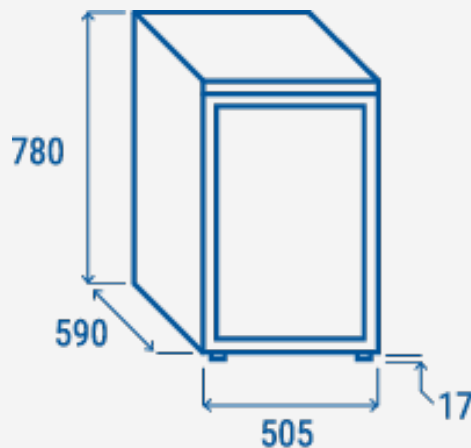
COOL HEAD EUROPE
 We make the world a cooler place

www.coolheadeurope.com